



BRAKE BOOSTER



CAM SHAFT



CARBURETOR



CLUTCH MASTER



CONNECTING ROD



CRANKSHAFT



CYLINDER LINER



ENGINE BEARING



PISTON



WATER PUMP



PISTON RING

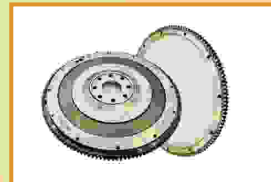

FLY WHEEL RING

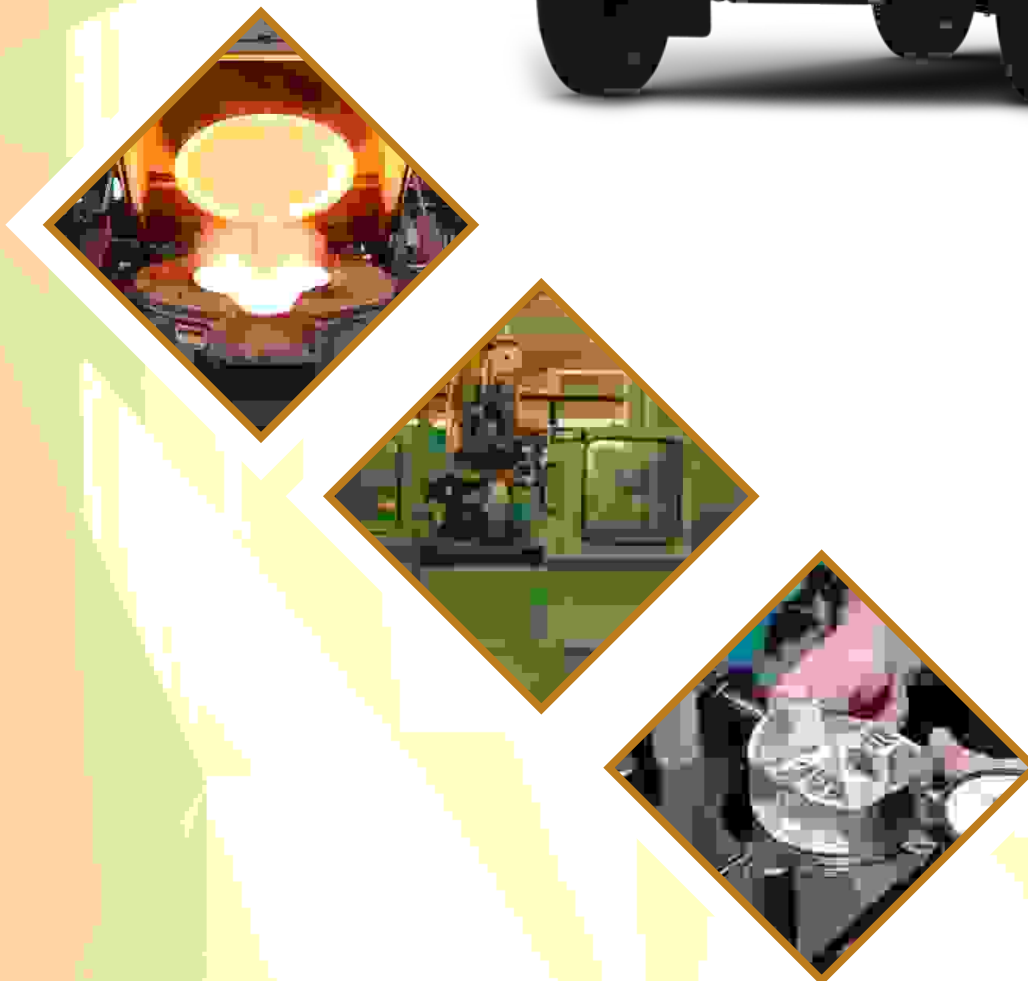
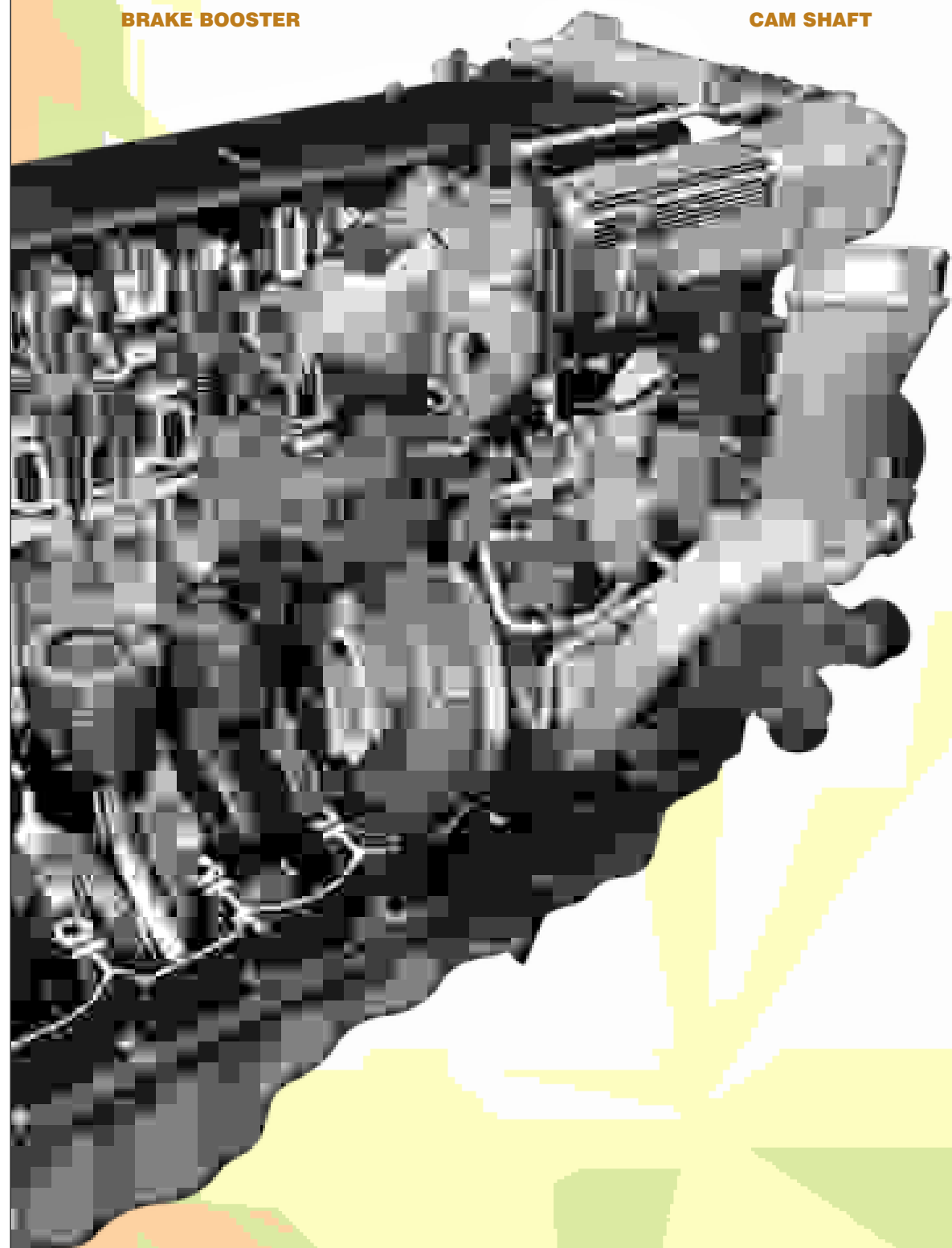

DURO POWER™

AUTOMAX INTERNATIONAL

46/2/4, Site-4, Sahibabad Industrial Area,
Near Indraprastha Dental College, Ghaziabad-201010, INDIA
Mob. : +919810665600, +918368041202
998983059364 (Tashkent), +7755948567 (Almaty)



DURO POWER™

Manufacturer & Distributor of Auto Spare Parts
AUTOMAX INTERNATIONAL

www.smsenterpriseindia.com



BALL BEARING

PARTS FOR
GAZ, VOLGA, URAL, LADA, KAMAZ, KARAZ, ZIL, CASE, PERKINS,
FORD, FORDSON, ZETOR, DUETZ ROMANIA,
RENAULT, IVECO, MESSY FERGUSON, BEDFORD, MERCEDES BENZ, DAF,
NEW HOLLAND, VOLVO, SCANIA, MACK
MITSUBISHI, TOYOTA, HONDA, ISUZU, NISSAN, HYUNDAI,
KOMATSU, CUMMINS, CATERPILLAR

AUTOMAX INTERNATIONAL was established as a
frontier of Auto component supplier from India.
We distribute Genuine, OEM and high Quality after
Market Products for Cars, Automobile, Agricultural
Tractor, Commercial Vehicles and Earth-Moving
equipments.

Our goal at AUTOMAX INTERNATIONAL is to distribute
high quality precision products at competitive prices with
our is at par at the best, and we take pride in catering to
some of the major global distributors. We believe in
long-term association with our customers, and support
them fully in their endeavors to excel in their areas of
operation.

With Promoters having Technical background and
Experience of more than 30 years in Engineering
Products, we pride in our second technical team to give
support to any issues pertaining to quality. We work very
closely with Design & Engineering team of our clients
and share views to bring out optimal solution in the best
interest and satisfaction of end users.

We enjoy the trust of our customers and work hard to
continue this confidence best showed on us.
Our primary focus is on Quality Control and Sound
Delivery Practices in all aspects.

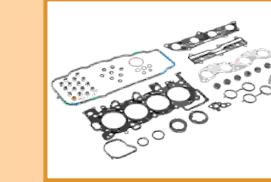

GASKET



IGNITION SWITCH



LEAF SPRING

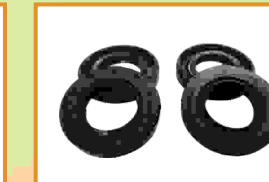

OIL SEAL

PISTON & PISTON PINS

The piston is a moving part of the combustion chamber. It is responsible for converting the energy released during the combustion process into mechanical work. The piston also performs a number of other important tasks: It seals the combustion chamber, guides the connecting rod, dissipates the heat generated in the combustion chamber, supports gas exchange, supports mixture preparation, carries the sealing elements (piston rings).

The piston is exposed to various forces.

• **Piston Force** When the engine is running, it moves up and down constantly in the cylinder. At each reversing point it is braked sharply and then accelerated again. This generates mass inertia forces which act on the piston. Together with the forces generated from the gas pressure, they form the piston force.

lateral force or normal force : This piston force is transmitted to connecting rod and the crankshaft. However, the connecting rod is only precisely vertical at the upper and lower reversing points (known as dead centre). The inclination of the connecting rod pushes the piston to the side, i.e. against the cylinder wall. The extent of this lateral force changes direction several times during an operating cycle. It is determined by the piston force and the angle of the piston crown in relation to the connecting rod axis. The lateral force can be derived from the parallelogram of forces.



PISTON RINGS

Every piston is fitted with piston rings. The piston rings must seal off the combustion chamber and the working space from the crankcase and strip the oil from the cylinder walls, thereby regulating oil consumption. They must also dissipate the heat absorbed by the piston during combustion to the cooled barrel. This is one of the most critical components in the combustion engine as the compression and the forces generated in the combustion are linked to the performance of the Ring Sealing Efficiency. There is a continuous development and design up gradation in the improving efficiency, performance and life of this precision part.

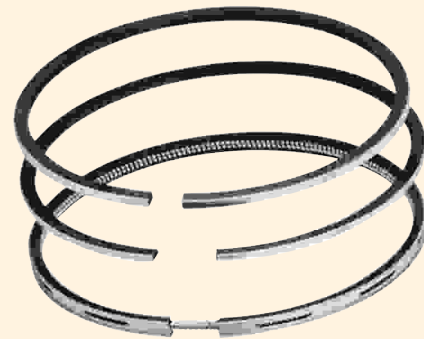

CYLINDER LINERS, SLEEVES & FINNED BLOCKS

The cylinders of a combustion engine form the working space and combustion chamber. The cylinders are also charged with the task of guiding the pistons as they move up and down and directing the heat generated during the combustion process to the cooling system. The cylinder wall is wetted with oil to ensure sufficient lubrication to pistons and piston rings moving up and down inside the cylinder.

Appropriate materials are selected to safeguard good heat transfer to the engine block or coolant. Depending on their design, cylinders can be made from different alloys of grey cast iron and may be Air Cooled, Air Cooled, Full or Semi Finish.



ENGINE BEARINGS, BUSHES & THRUST WASHERS

Function Plain bearings support and guide moving components inside the engine. Their primary purpose is to facilitate the virtually wear-free rotation of these components.

Function Plain bearings support and guide moving components inside the engine. Their primary purpose is to facilitate the virtually wear components. Plain bearings comprise one or two bearing shells which are locked firmly in place in the bearing seat. The bearing shells wrap around the rotating shaft at the bearing journals. Engine oil is pushed into the plain bearing through a bore hole. During normal operation of the engine, the shaft virtually guides above the film of oil without touching the bearing shell.

Plain bearings absorb the axial and radial forces, redirecting them to the bearing housing. Plain bearings are used both for rotating shafts

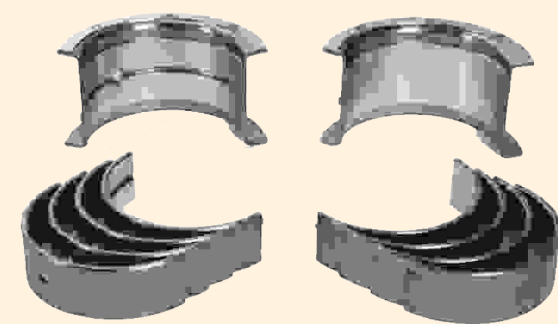

GASKETS & SEALING

Gaskets are highly technical and complex engine components. They are used in many different forms and material compositions in modern combustion engines and assemblies (gearboxes, axles, etc.).

The primary task of gaskets is to seal off the various media in the engine (including gases, water and oil) from both one another and the outside world. However, gaskets also function as power transmission links. Modern high-performance sealing systems are very reliable. Engine designers and component manufacturers have spent a great deal of time and effort developing product solutions, which can be relied upon for safe operation even under critical boundary conditions. Accordingly, modern sealing systems are able to withstand aggressive media, high pressures and equally high temperatures throughout the lifetime of a car.

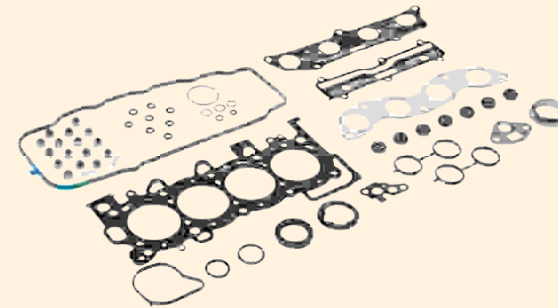

CONNECTING ROD

The connecting rod converts the linear up and down movement of the piston into the circular motion of the crankshaft and is therefore subject to tension, compression, bending and buckling.

The connecting rod is mounted on the crank pin of the crankshaft with a plain bearing. The connecting rod bearing cap is bolted to the big end. In most cases the connecting rod has an oil duct in its body to supply the gudgeon pin with lubricant.

To obtain minimal weight and high strength, connecting rods are made from different materials: Microalloyed steels; Sintered metals, High-grade aluminium, CFRP and titanium (for high-performance engines)

Forged connecting rods exhibit a better strength-to-weight ratio and lower costs than sintered connecting rods. Mass-produced connecting rods are forged, cast or sintered.



CRANKSHAFT

Crankshaft is part to convert Combustion power of the fuel-air mixture in the engine into rotary movement. The linear motion of the pistons is transmitted through connecting rod (link) into crankshaft passed to the flywheel (Inertia).

The crankshaft has to withstand considerable loads in this process. On the one hand it is subjected to severe bending and torsional stress. Further loads arise from torsional vibration, as the rotary movement of the crankshaft is constantly being abruptly accelerated and decelerated. The bearings are also subject to a high degree of wear.

To be able to withstand the strain of rotary movement, crankshafts need to have a hard surface and a tough core. For this reason forged crankshafts are most preferred. Alloyed heat-treated steel or nitrided steel is used as raw material. The crankshaft journals are also surface-hardened.

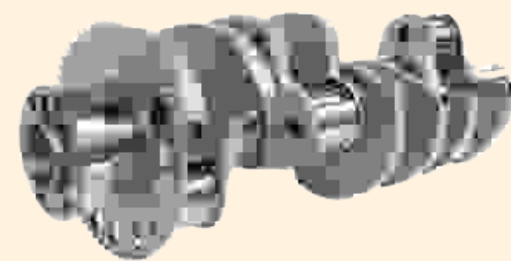

CAMSHAFT

The camshaft is a mechanical component of an internal combustion engine. It opens and closes the inlet and exhaust valves of the engine at the right time, with the exact stroke and in a precisely defined sequence. The camshaft is driven by the crankshaft by way of gearwheels, a toothed belt or a timing chain. With a transmission ratio of 2:1, the rate of rotation of the camshaft is half that of the crankshaft.

Camshafts are made from the following materials.

- Grey cast iron
- Ductile cast iron
- Heat-treated steel
- Nitrided steel

They can be of hollow design to save weight. Their bearings and the cam tracks are usually surface-hardened or available separately or as a kit. In addition to the camshaft, kits include the corresponding bucket tappets, rockers or rocker arms.



ENGINE VALVES

Valves are nitrided to increase the exhaust strength, chrome plated to increase the wear resistance and Stellite (Seat hard Faced) to get high not hardness at the seat.

We use high grade Bi-metal chromium silicon alloy series EN159 (214N) to manufacture valves which make them resistant to corrosion due to presence of hot gases and high temperature.

Our engine valves withstand harsh operating conditions of hot gases and high temperatures and deliver more than expected performance as they are made of the finest alloy steel which helps it to remain stable under extreme working conditions. We offer both intake and exhaust valves.

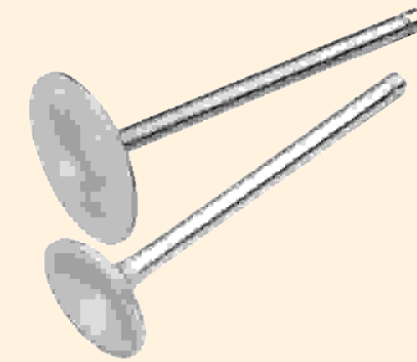

LEAF SPRING

The suspension system of a Truck/car plays a major role in its working. The car's suspension is directly related to the comfort a passenger can experience when driving his car.

The main purpose of the car's suspension is to absorb the bumps which one finds invariably on the roads we drive on. If these bumps would not be absorbed by a dedicated system, cars might even lose touch with the road when traversing the bump, leading to loss of control. Thus, the need arises for a suspension system.

We are manufacturing Parabolic Leaf Springs, Multi Leaf Springs, Mechanical Trailer Suspension Assemblies, Trailer Leaf Springs, U-bolts and Leaf Spring Bushes for almost all kinds of Truck & Trailers. Our goods are well suited for the Heaviest of Vehicles & the Toughest of Terrains.



FLYWHEEL & RING GEAR

A flywheel is a mechanical device specifically designed to efficiently store rotational energy. Flywheels resist changes in rotational speed by their moment of inertia. The amount of energy stored in a flywheel is proportional to the square of its rotational speed. The way to change a flywheel's stored energy is by increasing or decreasing its rotational speed by applying a torque aligned with its axis of symmetry. Flywheels are often used to provide continuous power output in systems where the energy source is not continuous.

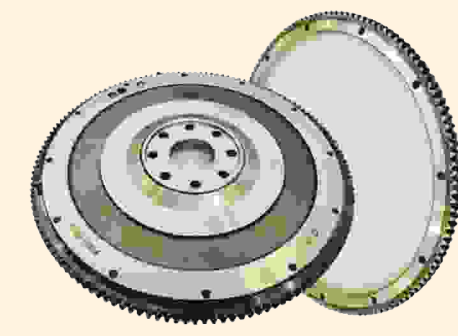

CYLINDER HEAD

The cylinder head has the following tasks:

- Sealing between the combustion chamber and cylinder block.
- Forming the shape of the combustion chamber
- Dissipating the heat from the combustion process. It contains the most important mechanical components for controlling the gas exchange process comprising of:
 - Inlet and outlet ports of the cylinders
 - Valve control
 - Oil ducts for lubricating the valve train
 - Coolant ducts Spark plugs (on petrol engines)

Injection valves (on petrol engines with direct injection)

- Injection nozzles and glow plugs (on diesel engines)

The cylinder-head gasket is sandwiched between the engine block and the cylinder head.

Its construction design essentially influences the operating characteristics and performance of the engine.

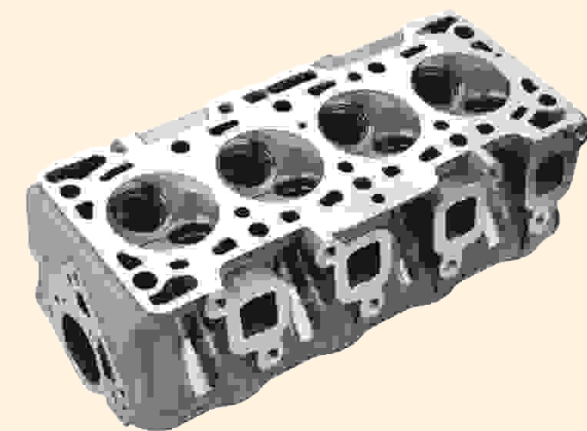

WATER PUMPS & OIL PUMPS

Water Pump function is to drive the coolant to continue to circulate in the system. This facilitates the cooling system to release the heat generated by the engine in the best possible way.

The oil pump is driven by the crankshaft gear or camshaft and is responsible for building up the oil pressure to maintain flow and circulation of oil in the lubrication system.

One of the tasks of an oil pump is to provide an oil film between the working surfaces. Oil film between the working parts must be sufficiently strong to minimize potential contact between metal surfaces in motion, under all conditions of engine operation. This reduces friction and its consequences, hence unnecessary power consumption, heating and depletion of engine parts.

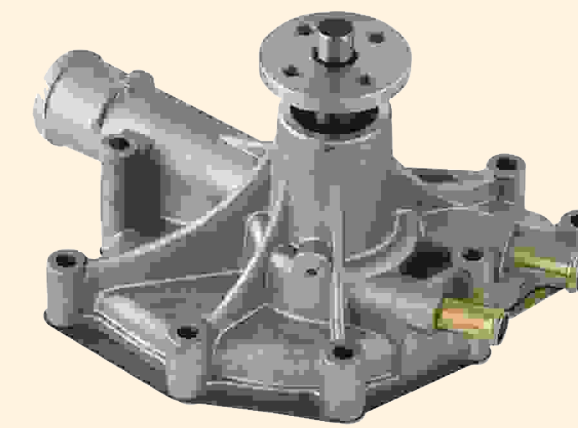

RELAYS

Automobile relay is a kind of important electronic component, auto parts which are widely used in the control car start, preheating, air conditioning, lights, wiper, efi, oil pump, security, audio, communications, navigation, electric fan, cooling fan, electric Windows, air bags, anti-lock braking and suspension control and automotive electronic instrument and fault diagnosis system, is second only to automotive electronic sensors in automobile products one of the most used car electronic components.

We are specialized in automotive electronic accessories such as auto relays, auto flashers, auto wiper relays etc.

We are constantly pursuing the superior quality of our products. Professional team, excellent automatic machine and testing equipment guarantee the excellent quality.

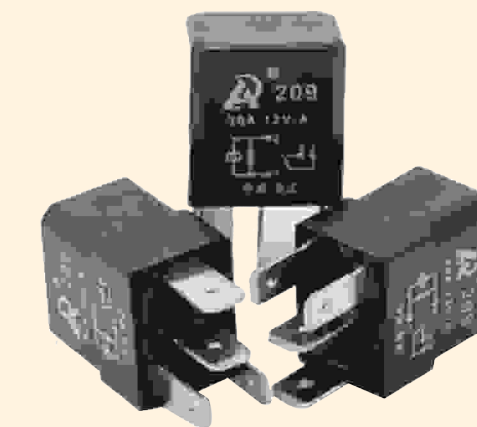

IGNITION SWITCHES

An ignition switch, starter switch is a switch in the control system of a motor vehicle that activates the main electrical systems for the vehicle, including "accessories" (radio, power windows, etc.). In vehicles powered by internal combustion engines, the switch provides power to the starter solenoid and the ignition system components (including the engine control unit and ignition coil), and is frequently combined with the starter switch which activates the starter motor. Our ignition switches are key switches that require the proper key to be inserted in order for the switch functions to be unlocked. With well-equipped testing facilities and strong technical force, each product will be 100% inspected before sending to customer's hand.

